

## Test report # PF21065

**Test Number 21065**

**Client: Parchem Construction Supplies Pty Ltd**

**Fire resistance tests for wall linear gaps**

**Test method: AS 1530.4:2014**

Report Date 02/11/2021

## 1. Table of Contents

---

1.	Table of Contents .....	2
1.1	Document revision schedule .....	3
1.2	Signatories .....	3
2.	Contact details.....	4
2.1	IANZ registered Testing Authority .....	4
2.2	Client/Applicant.....	4
2.3	Manufacturer.....	4
3.	Test Results .....	5
4.	Test Details.....	6
5.	Equipment.....	8
6.	Test Conditions.....	9
6.1	Furnace Temperature.....	9
6.2	Ambient Temperature.....	9
6.3	Pressure Readings.....	10
7.	Schedule of materials.....	11
8.	Test Specimens details .....	12
8.1	Thermocouple Positions Table .....	12
8.2	Observations.....	14
9.	Separating element .....	16
10.	Specimens .....	17
10.1	Specimen A.....	18
10.2	Specimen B .....	20
10.3	Specimen C .....	22
10.4	Specimen D.....	24
11.	Additional photographs.....	26
11.1	During and after the test .....	26

## 1.1 Document revision schedule

Revision #	Date	Description
1	28/10/2021	Initial Issue for Client review
2	02/11/2021	Issued with Client comments

## 1.2 Signatories

Report	Name	Signature	Date
Prepared by:	Alexey Kokorin (Technical Manager)		02/11/2021
Authorized by:	Andrew Bain (Authorized signatory)		02/11/2021



All tests reported herein have been performed in accordance with the laboratory's scope of accreditation

## 2. Contact details

---

### 2.1 IANZ registered Testing Authority

Passive Fire Inspection and Test Services Ltd

Accreditation N<sup>o</sup>: 1335

1/113 Pavilion Drive, Mangere, Auckland, 2022

New Zealand

Contact e-mail: [tests@firelab.co.nz](mailto:tests@firelab.co.nz)

### 2.2 Client/Applicant

Parchem Construction Supplies Pty Ltd

1956 Dandenong Rd Clayton, VIC,

Australia

Contact e-mail: [phil.jones@parchem.co.nz](mailto:phil.jones@parchem.co.nz)

### 2.3 Manufacturer

Same as Client/Applicant

## 3. Test Results

Specimen #	Joint	Actual Integrity (min)	Actual insulation (min)	FRL**
A*	20mm Butt-joined Vertical Linear Joint, 20mm deep sealant on fire side only	250NF	50	-/240/30
B*	20mm Butt-joined Vertical Linear Joint, 10mm deep sealant on non-fire side only	250NF	107	-/240/90
C	20mm Butt-joined Vertical Linear Joint, 10mm deep sealant on both sides	250NF	166	-/240/150
D*	20mm Butt-joined Vertical Linear Joint, 10mm deep sealant on fire side only	250NF	28	-/240/-

\* - asymmetrical one-way system, the rating applied if exposed to fire as tested.

\*\* - FRL shall be limited by the performance of separating element

NF – No failure during the test

This report shall not be reproduced, except in full.

The test results relate to the specimens of the product in the form in which they were tested. Differences in the composition or thickness of the product may significantly affect the performance during the test and may therefore invalidate the test results. Care should be taken to ensure that any product, which is supplied or used, is fully represented by the specimens, which were tested.

The specimens were supplied by the sponsor and the Laboratory was not involved in any of selection or sampling procedures.

The results of these fire tests may be used to directly assess fire hazard, but it should be recognized that a single test method will not provide a full assessment of fire hazard under all fire conditions.

## 4. Test Details

---

### **Test Specification Fire Resistance:**

Failure shall be deemed to have occurred when one of the following occurs:

- a) the temperature at any location on the unexposed face of the test specimen exceeds the initial temperature by more than 180 °C
- b) Integrity failure shall be deemed to have occurred upon ignition of the cotton pad when glowing or flaming occurs or for a period of 30 seconds.
- c) Flaming to the unexposed face for 10 seconds or longer shall be deemed to be an Integrity failure.

### **Testing scope:**

AS 1530-2014 Part 4 Section 10 Service penetrations and control joints

AS 4072.1-2005 Part 1 Appendix A - Typical examples of fire-stopping systems for movement joints.

### **Documentation:**

Testing products were verified and tested based on Client description, refer to Specimens description below.

### **Testing date:**

21/10/2021

### **Installation completion date:**

27/09/2021

### **Specimens conditioning and delivery to Laboratory:**

Separating element was built by Laboratory in line with Client instructions. Installation of fire stopping system was performed by Laboratory. The Laboratory was not involved in sampling of the materials. Laboratory verified materials during construction of the specimen.

### **Termination of The Test:**

The test was discontinued at 250 minutes.

**Use of Reports:**

This report shall not be reproduced, except in full.

This report details the methods of construction, test conditions and the results obtained when the specific element of construction described herein was tested following the procedure outlined in AS 1530.4. Any significant variation with respect to size, constructional details, loads, stresses, edge or end conditions, other than that allowed under the field of direct application in the relevant test method, is not covered by this report.

Because of the nature of fire resistance testing and the consequent difficulty in quantifying the uncertainty of measurement of fire resistance, it is not possible to provide a stated degree of accuracy of the result.

## 5. Equipment

---

### **Furnace:**

1200X1200 Indicative Furnace designed to operate to AS1530.4:2014

### **Temperature:**

Furnace Temperature measurements were controlled with four 3mm Type K MIMS thermocouples set within 50-100 mm from the face of the specimens in line with AS1530.4-2014. All thermocouples are calibrated by ISO/IEC 17025 accredited laboratory - a signatory to the International Laboratory Accreditation Corporation (ILAC) through their Mutual Recognition Agreement (MRA) to the accuracy required by AS 1530.4-2014.

### **Pressure measurement:**

Kepware Siemens Data logging system including multi-channel recording data at 5 second intervals. Calibrated by ISO/IEC 17025 accredited laboratory - a signatory to the International Laboratory Accreditation Corporation (ILAC) through their Mutual Recognition Agreement (MRA) to the accuracy required by AS 1530.4-2014.

### **Ambient Temperature:**

Ambient temperature was recorded 15 minutes before the test was commenced, at the start of the test and monitored during the test. All thermocouples are calibrated by ISO/IEC 17025 accredited laboratory - a signatory to the International Laboratory Accreditation Corporation (ILAC) through their Mutual Recognition Agreement (MRA) to the accuracy required by AS 1530.4-2014.

### **Specimen thermocouples:**

Specimen thermocouples were installed to the unexposed face. Type K copper disk thermocouples fixed within the required locations referenced from AS1530.4-2014. Thermocouples are calibrated by ISO/IEC 17025 accredited laboratory - a signatory to the International Laboratory Accreditation Corporation (ILAC) through their Mutual Recognition Agreement (MRA) to the accuracy required by AS 1530.4-2014.

### **Dimensional measurements:**

All linear measurements are made with equipment calibrated by ISO/IEC 17025 accredited laboratory - a signatory to the International Laboratory Accreditation Corporation (ILAC) through their Mutual Recognition Agreement (MRA) to the accuracy required by AS 1530.4-2014.



## 6. Test Conditions

### 6.1 Furnace Temperature

The furnace was controlled to follow the temperature/time relationship specified in AS 1530.4-2014 as closely as possible.

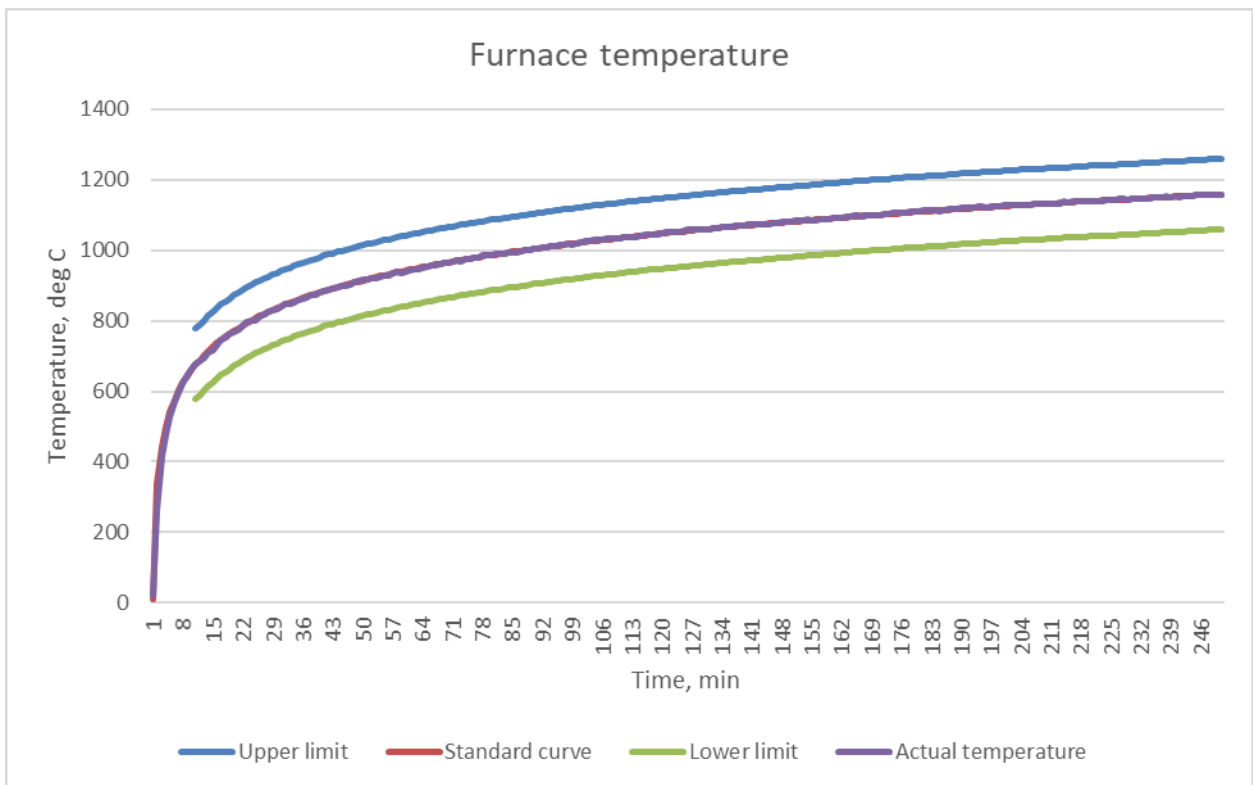

### 6.2 Ambient Temperature

The ambient temperature of the test area 15 minutes before the test and at the commencement of the test was 20 °C.

## 6.3 Pressure Readings

After the first 5 minutes of the test, the furnace pressure was maintained at  $16 \pm 3$  Pa with respect to atmosphere. The probe was located 500mm above the furnace floor.

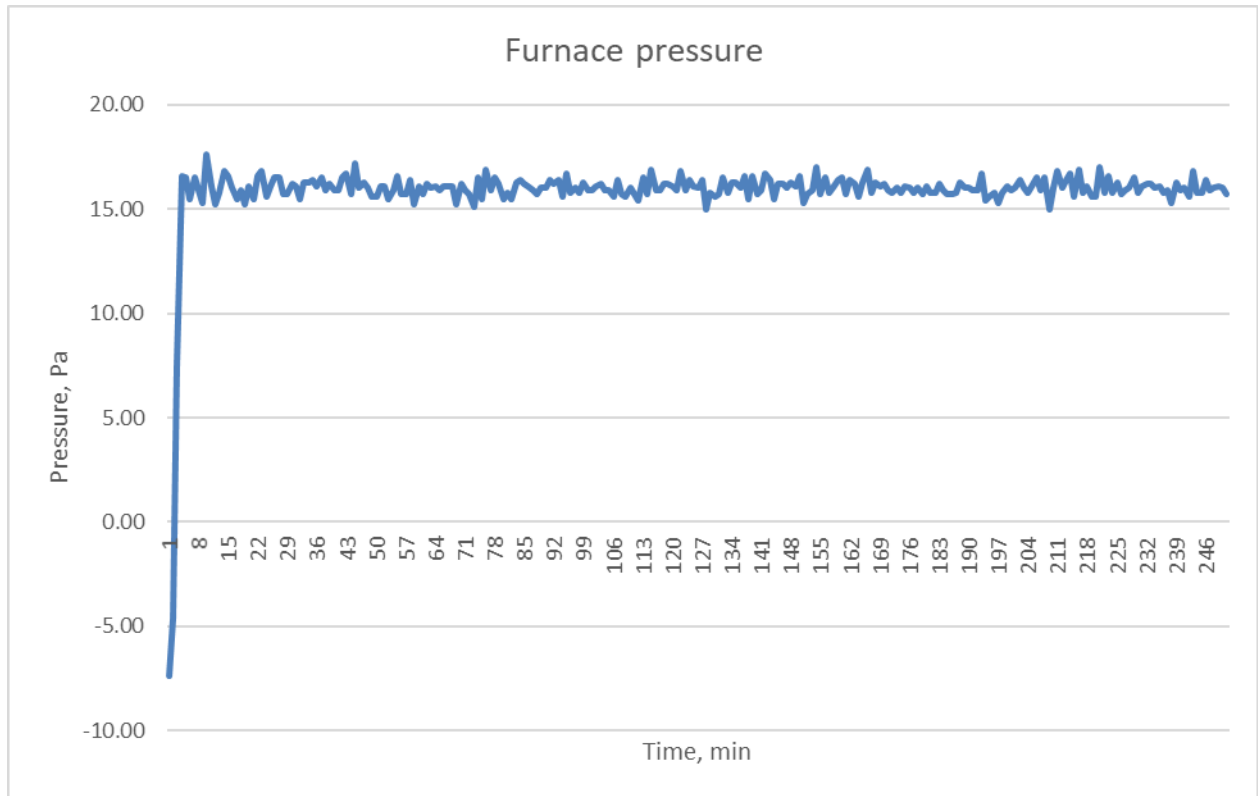

## 7. Schedule of materials

All firestopping products were supplied by Client.

<b>Separating Element</b>		
1.1	Item / Product Name	Concrete Slab Separating element
	Measurements	1200mm x 1200mm
	Thickness	120mm (nominal)
1.2	Item / Product Name	Concrete Slab
	Measurements	Width / Height (W/H): 1440mm x 1260mm
		Thickness (T): 140mm (nominal)
	Additional Info	Used to construct separating element.
1.3	Item / Product Name	Galvanised steel angle
	Measurements	Width / Height (W/H): 50mm x 50mm
		Thickness (T): 1mm
	Additional Info	Used to fix concrete slabs to refractory frame

<b>Sealants</b>		
3.1	Item / Product Name	Fosroc Flamex One
	Measurements	600mL tube
	Installation	Inserted into separating element gaps

<b>Fixings/Miscellaneous Items</b>		
4.1	Item / Product Name	Ramset ShureDrive Mushroom Head Anchor Drive
	Measurements	6 x 30mm
	Installation	Used to fix concrete slabs to steel angle
4.2	Item / Product Name	Sika PEF Backing Rod
	Measurements	25mm
	Installation	Placed in separating element gaps to ensure correct sealant depth

## 8. Test Specimens details

---

### 8.1 Thermocouple Positions Table

Sp#	TC#	THERMOCOUPLE LOCATION DESCRIPTION
A	1	Separating element, 25mm left of Specimen A, 200mm below top edge of Concrete Slab
A	2	Separating element, 25mm right of Specimen A, 200mm below top edge of Concrete Slab
A	3	Separating element, 25mm left of Specimen A, vertical centre of Concrete Slab
A	4	Separating element, 25mm right of Specimen A, vertical centre of Concrete Slab
A	5	Separating element, 25mm left of Specimen A, 200mm above bottom edge of Concrete Slab
A	6	Separating element, 25mm right of Specimen A, 200mm above bottom edge of Concrete Slab
B	7	Separating element, 25mm left of Specimen B, 200mm below top edge of Concrete Slab
B	8	Separating element, 25mm right of Specimen B, 200mm below top edge of Concrete Slab
B	9	Separating element, 25mm left of Specimen B, vertical centre of Concrete Slab
B	20	Separating element, 25mm right of Specimen B, vertical centre of Concrete Slab
B	11	Separating element, 25mm left of Specimen B, 200mm above bottom edge of Concrete Slab
B	12	Separating element, 25mm right of Specimen B, 200mm above bottom edge of Concrete Slab
B	13	Separating element, 25mm left of Specimen C, 200mm below top edge of Concrete Slab
C	14	Separating element, 25mm right of Specimen C, 200mm below top edge of Concrete Slab

C	15	Separating element, 25mm left of Specimen C, vertical centre of Concrete Slab
C	16	Separating element, 25mm right of Specimen C, vertical centre of Concrete Slab
C	17	Separating element, 25mm left of Specimen C, 200mm above bottom edge of Concrete Slab
C	18	Separating element, 25mm right of Specimen C, 200mm above bottom edge of Concrete Slab
D	19	Separating element, 25mm left of Specimen D, 200mm below top edge of Concrete Slab
D	20	Separating element, 25mm right of Specimen D, 200mm below top edge of Concrete Slab
D	21	Separating element, 25mm left of Specimen D, vertical centre of Concrete Slab
D	22	Separating element, 25mm right of Specimen D, vertical centre of Concrete Slab
D	23	Separating element, 25mm left of Specimen D, 200mm above bottom edge of Concrete Slab
D	24	Separating element, 25mm right of Specimen D, 200mm above bottom edge of Concrete Slab
B	25	On sealant, centre of 20mm sealed aperture, 200mm below top edge of Concrete Slab
B	26	On sealant, centre of 20mm sealed aperture, vertical centre of Concrete Slab
B	27	On sealant, centre of 20mm sealed aperture, 200mm above bottom edge of Concrete Slab
C	28	On sealant, centre of 20mm sealed aperture, 200mm below top edge of Concrete Slab
C	29	On sealant, centre of 20mm sealed aperture, vertical centre of Concrete Slab
C	30	On sealant, centre of 20mm sealed aperture, 200mm above bottom edge of Concrete Slab
SE	31	Separating element, Mid-width of the centre Concrete Slab, 400mm below top edge of Concrete Slab

## 8.2 Observations

Time Minutes	Test Face	SP#	Observations
5	E	C, D	Visible combustion of seal, expansion with surface cracks
5	E	A	No expansion, small Visible combustion
5	E	A	Visible expansion near top half of seal
9	U	D	Visible smoke protruding from the top of the seal
13	U	D	Visible brown marks on PEF Rod
15	E	D	Visible cracking/gap near top quarter of seal
17	E	A	Further expansion of mastic seal, visible discoloured line and cracking throughout seal
23	U	A	Visible discolouring of PEF rod near TC3 and TC4, smoke protruding from area
<b>28</b>	<b>U</b>	<b>D</b>	<b>Roving thermocouple applied to seal - exceeded 200°C - Insulation failure</b>
28	E	D	Further expansion of seal, visible gaps remain near top quarter
28	E	C	Further expansion of seal
30	E	A	Further expansion of seal
30	E	A	Visible crack in mastic remains
32	U	C	Visible discolouring and smoke from top of the seal
32	U	B	Visible bubbling of the seal above TC 7 and TC8
35	U	A	Visible deforming of the PEF rod
44	U	SE	TC13 removed from test due to moisture of the separating element
44	U	B	Visible expansion
50	U	A	<b>Roving thermocouple applied to seal - exceeded 200°C - Insulation failure</b>
60	E	ALL	No notable changes
65	U	B	Further visible expansion of sealant

75	U	A	Further visible deforming of the PEF rod
75	U	D	Visible white discolouring within aperture
88	U	A	Dark discolouring and dark yellow liquid residue from PEF rod
88	U	B	Further expansion above TC 13 and TC14
105	U	D	Visible red glow through small gap in seal
118	U	D	Cotton Pad test above gap for 30 seconds – PASS
142	U	B	Visible discolouring and charring between separating element and sealant junction
142	U	SE	Visible surface cracks of concrete panels near the bottom
148	U	D	Cotton pad test at 2 locations where small gaps have formed for 30 seconds - PASS
148	U	A	Seal visibly discoloured to white
150	U	B	Cotton pad test for 30 seconds above TC7 and TC8 – Pass
165	U	B	Further discolouring of junctions
165	U	C	Visible smoke from seal near TC17 and TC18
165	U	D	Red glow above TC23 and TC24 becoming more pronounced
178	U	D	Cotton pad test at 2 locations where small gaps have formed for 30 seconds - PASS
178	U	B	Visible discolouring of sealant surface
178	U	B	Cotton pad test for 30 seconds - Pass
195	U	A	Visible red glow forming
195	E	ALL	No notable changes
200	U	C	Large amount of expansion of seal
200	U	B	Visible discolouring on most of the surface of the seal
225	U	B, C	Further expansion with discolouring near the sides of the seal
240	U	B, C, D	Cotton pad test for 30 seconds - Pass
250			TEST DISCONTINUED

**Key: U = unexposed face. E = Exposed face.**

## 9. Separating element

Concrete Slab (1.2) was cut into 5 slabs with a width of 200mm (nominal) and a height of 1195mm (nominal). The cut concrete slabs were placed in the refractory frame and fixed using steel angle (1.3) and drive anchors (4.1). The horizontal spacing between each concrete slab was measured to be 20mm. The spacing between outer concrete slabs and the refractory frame was packed using ceramic fibre.

### Separating element temperature

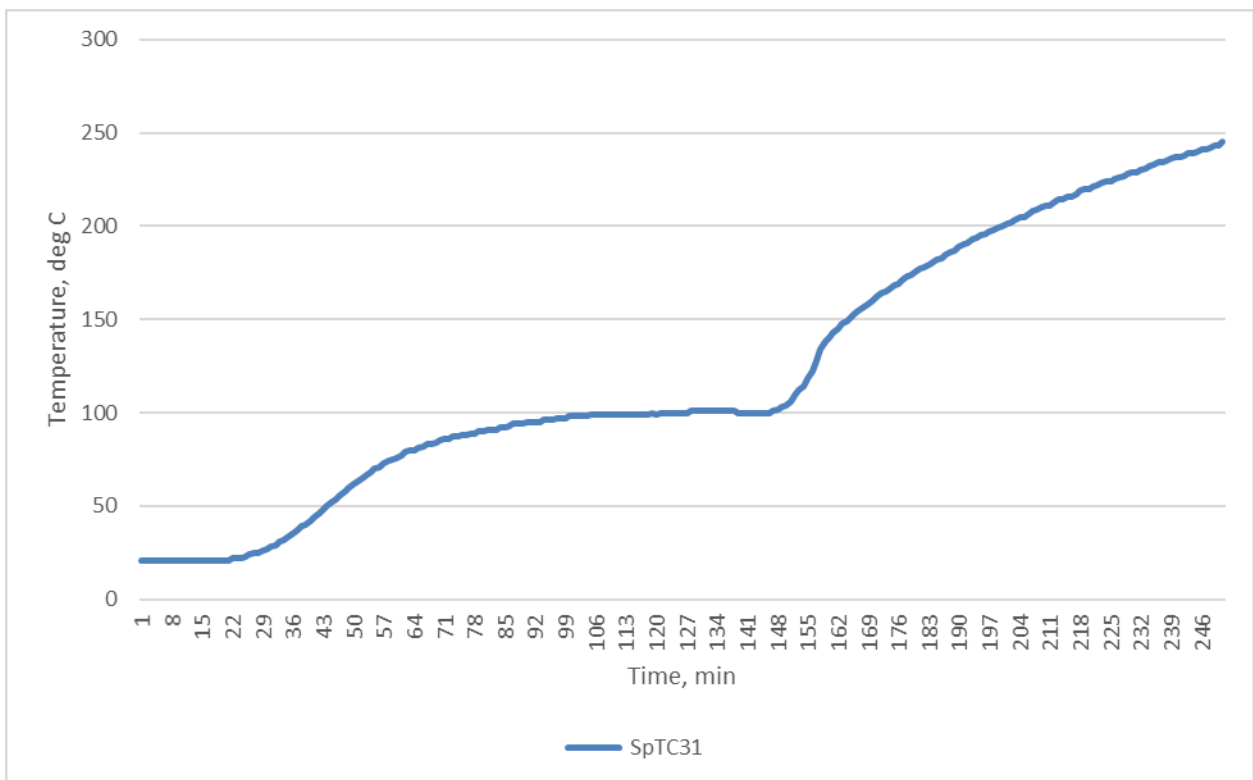



## 10. Specimens

---

Unexposed faced:

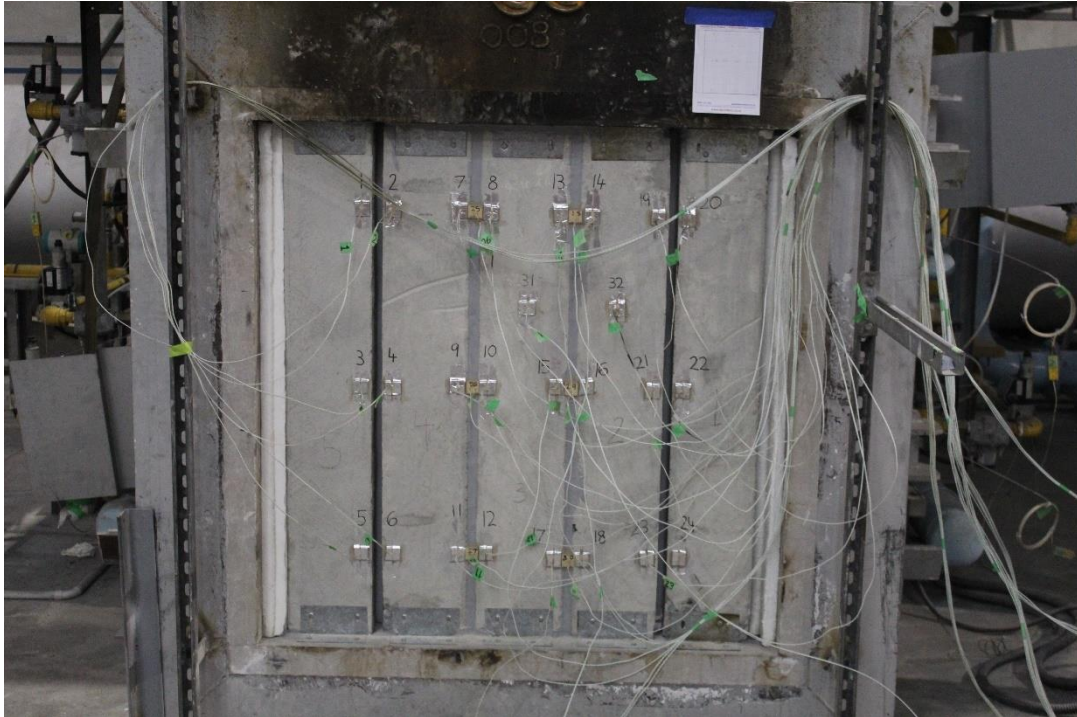

Exposed face:



## 10.1 Specimen A

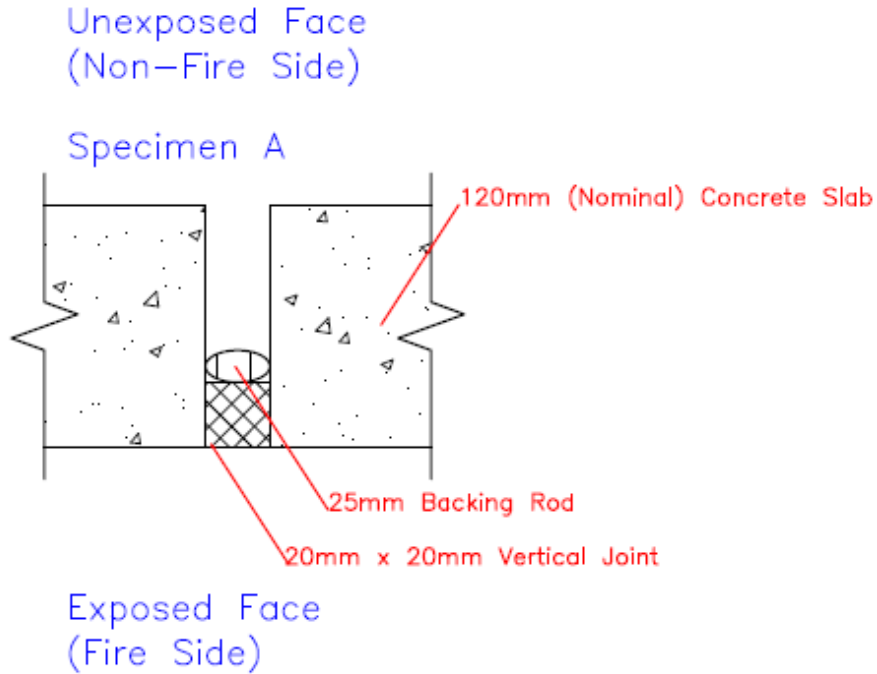

Penetration System		
A	Service	20mm Butt-joined Vertical Linear Joint
	Joint Details	Sealant (3.1)
	Aperture Size	Width/Height (W/H): 20mm x 1200mm
	<b>Local Fire-stopping Protection</b>	
	Application	Asymmetrical
Protection Used	PEF Backing rod (4.2) was pressed into the Concrete Slab (1.2) separating element gap from the exposed face. PEF rod was recessed 20mm from the surface. Sealant (3.1) was applied on top of the PEF rod, flush with the separating element faces, resulting in a 20mm (nominal) depth of sealant along the aperture.	

## Test results

<b>Structural adequacy</b>	<b>Not applicable</b>
<b>Integrity</b>	<b>No failure at 250 min</b>
<b>Insulation</b>	<b>50 min</b>

### Specimen A Thermocouples Readings

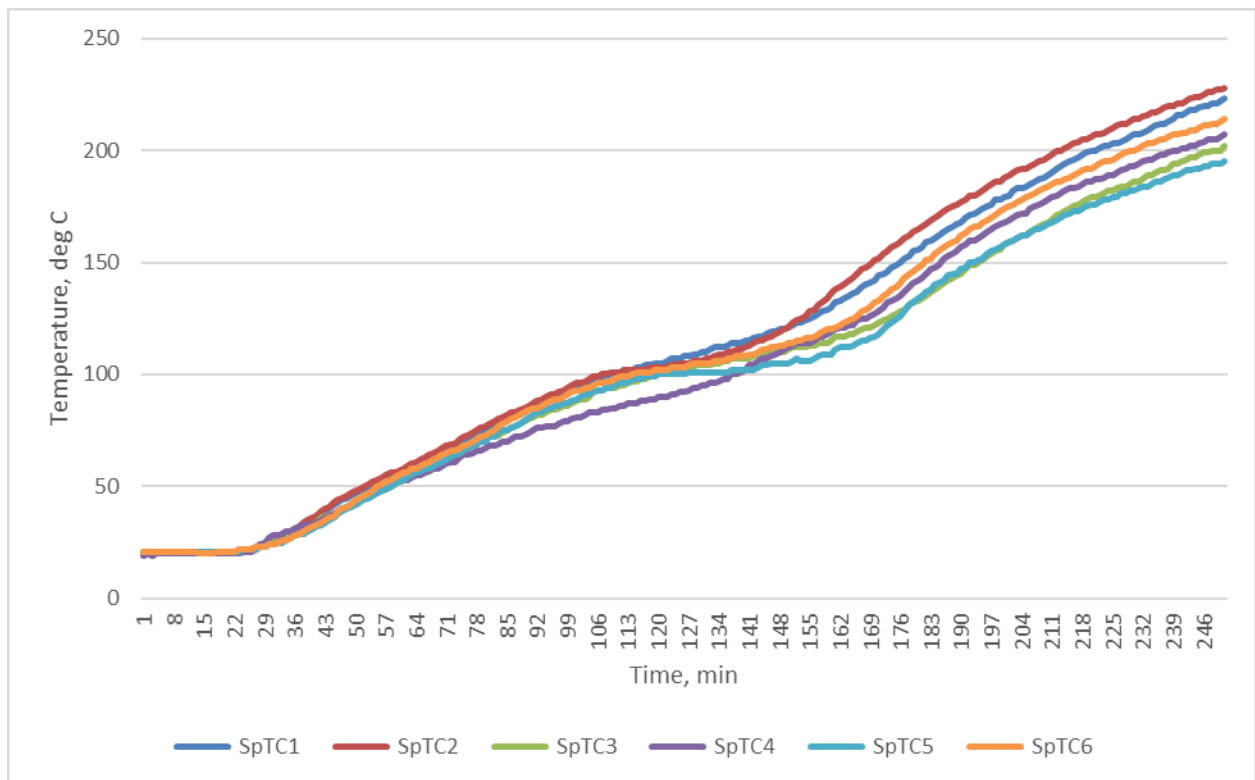

Roving thermocouple was applied to seal at 50 minutes, temperature exceeded 200°C - Insulation failure.

## 10.2 Specimen B

Unexposed Face  
(Non-Fire Side)

Specimen B

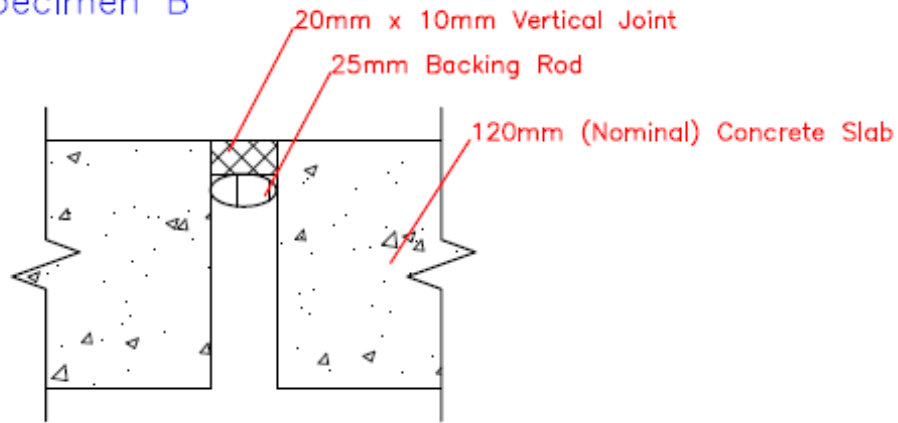

Exposed Face  
(Fire Side)

Penetration System		
B	Service	20mm Butt-joined Vertical Linear Joint
	Joint Details	Sealant (3.1)
	Aperture Size	Width/Height (W/H): 20mm x 1200mm
	<b>Local Fire-stopping Protection</b>	
	Application	Asymmetrical
	Protection Used	PEF Backing rod (4.2) was pressed into the Concrete Slab (1.2) separating element gap from the unexposed face. PEF rod was recessed 10mm from the surface. Sealant (3.1) was applied on top of the PEF rod, flush with the separating element face, resulting in a 10mm (nominal) depth of sealant along the aperture.

## Test results

<b>Structural adequacy</b>	<b>Not applicable</b>
<b>Integrity</b>	<b>No failure at 250 min</b>
<b>Insulation</b>	<b>107 min</b>

### Specimen B Thermocouples Readings

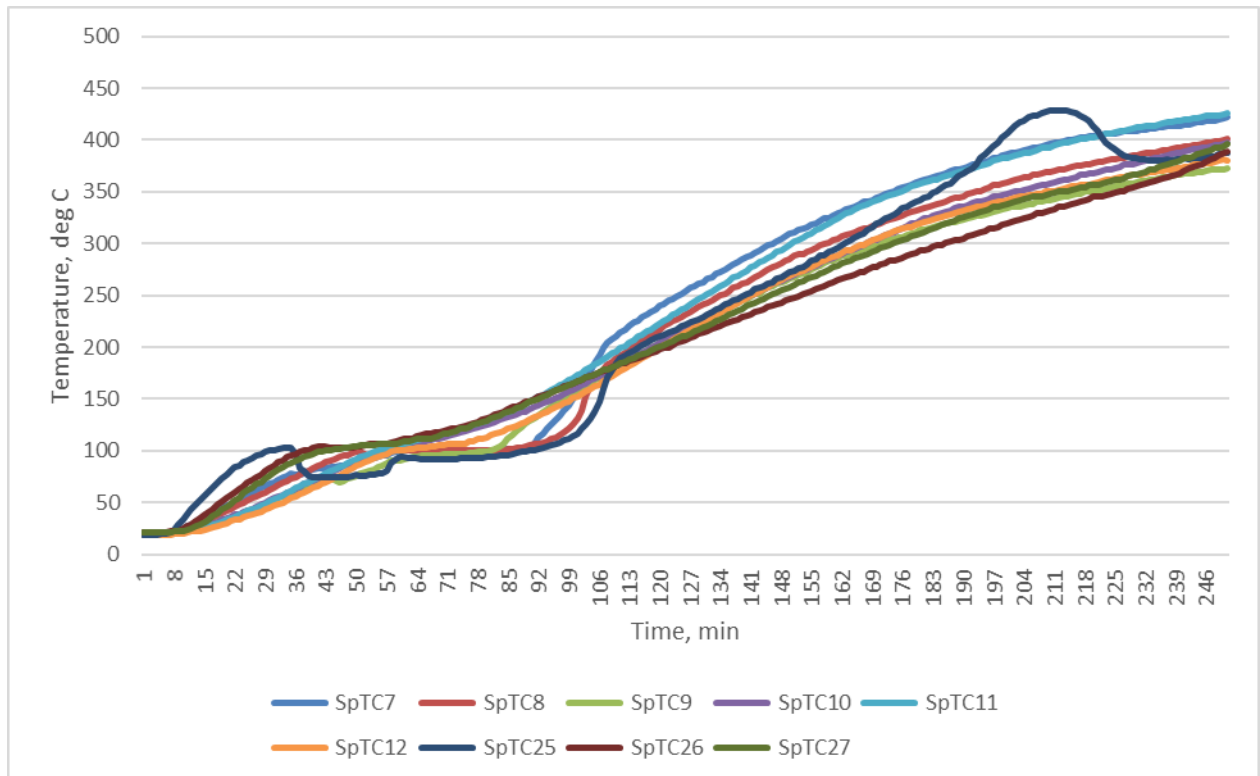

## 10.3 Specimen C

Unexposed Face  
(Non-Fire Side)

Specimen C

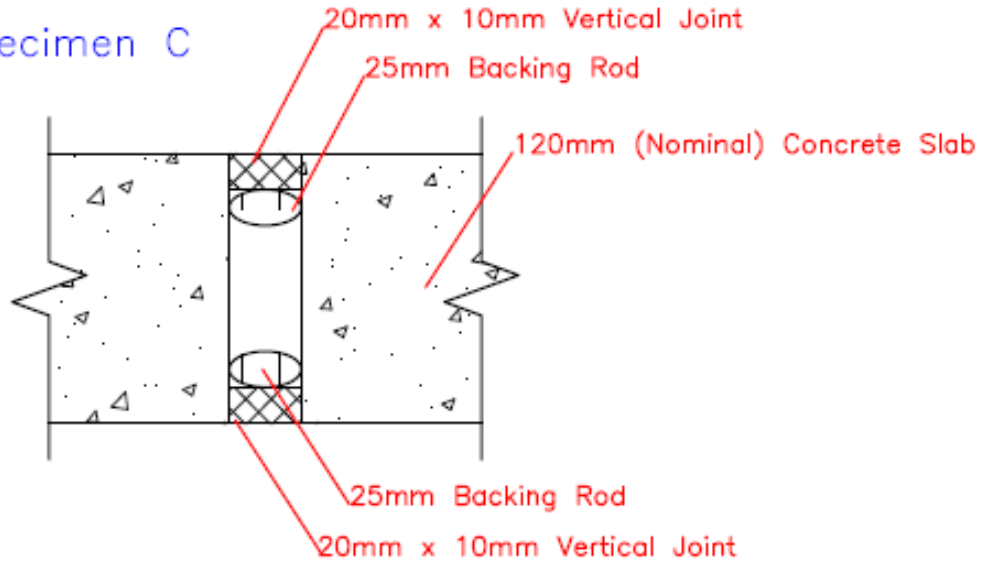

Exposed Face  
(Fire Side)

Penetration System		
C	Service	20mm Butt-joined Vertical Linear Joint
	Joint Details	Sealant (3.1)
	Aperture Size	Width/Height (W/H): 20mm x 1200mm
<b>Local Fire-stopping Protection</b>		
	Application	Symmetrical
	Protection Used	PEF Backing rod (4.2) was pressed into the Concrete Slab (1.2) separating element gap from both faces. PEF rod was recessed 10mm from the surfaces. Sealant (3.1) was applied on top of the PEF rods, flush with the separating element faces, resulting in a 10mm (nominal) depth of sealant along the aperture.

## Test results

<b>Structural adequacy</b>	<b>Not applicable</b>
<b>Integrity</b>	<b>No failure at 250 min</b>
<b>Insulation</b>	<b>166 min</b>

### Specimen C Thermocouples Readings

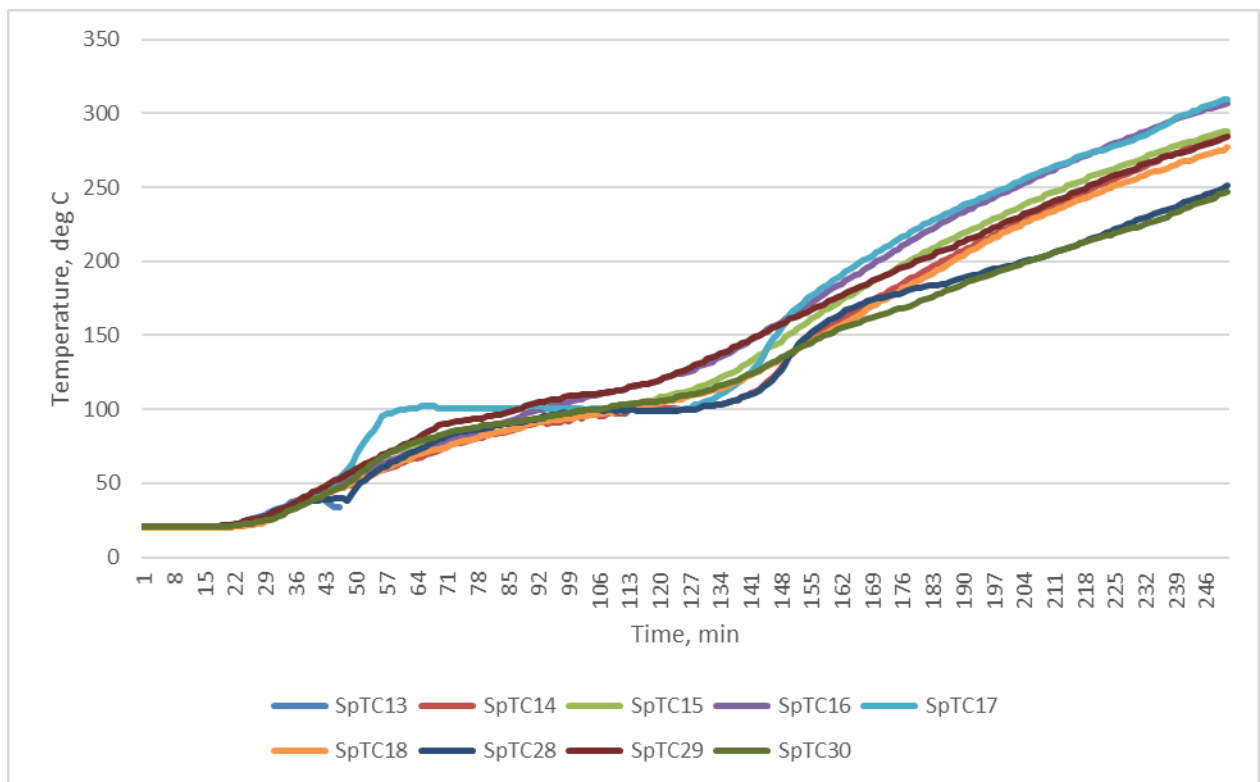

## 10.4 Specimen D

Unexposed Face  
(Non-Fire Side)

Specimen D

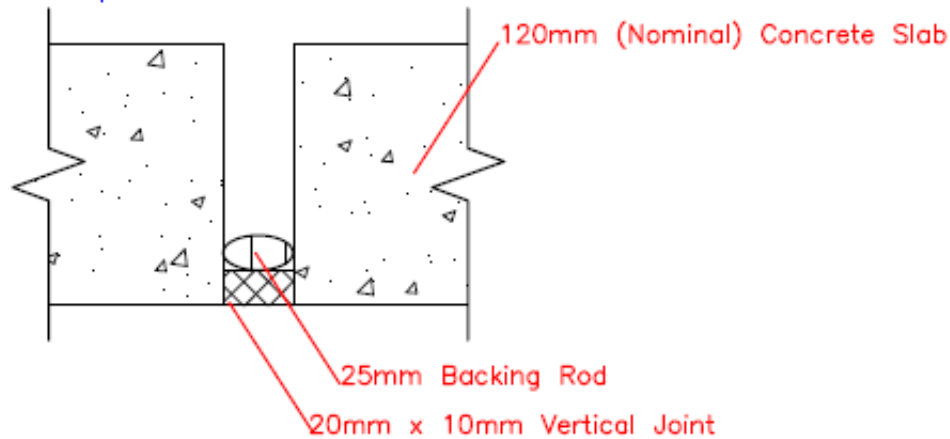

Exposed Face  
(Fire Side)

Penetration System		
D	Service	20mm Butt-joined Vertical Linear Joint
	Joint Details	Sealant (3.1)
	Aperture Size	Width/Height (W/H): 20mm x 1200mm
Local Fire-stopping Protection		
	Application	Asymmetrical
	Protection Used	PEF Backing rod (4.2) was pressed into the Concrete Slab (1.2) separating element gap from the exposed face. PEF rod was recessed 10mm from the surface. Sealant (3.1) was applied on top of the PEF rod, flush with the separating element face, resulting in a 10mm (nominal) depth of sealant along the aperture.



## Test results

<b>Structural adequacy</b>	<b>Not applicable</b>
<b>Integrity</b>	<b>No failure at 250 min</b>
<b>Insulation</b>	<b>28 min</b>

### Specimen D Thermocouples Readings

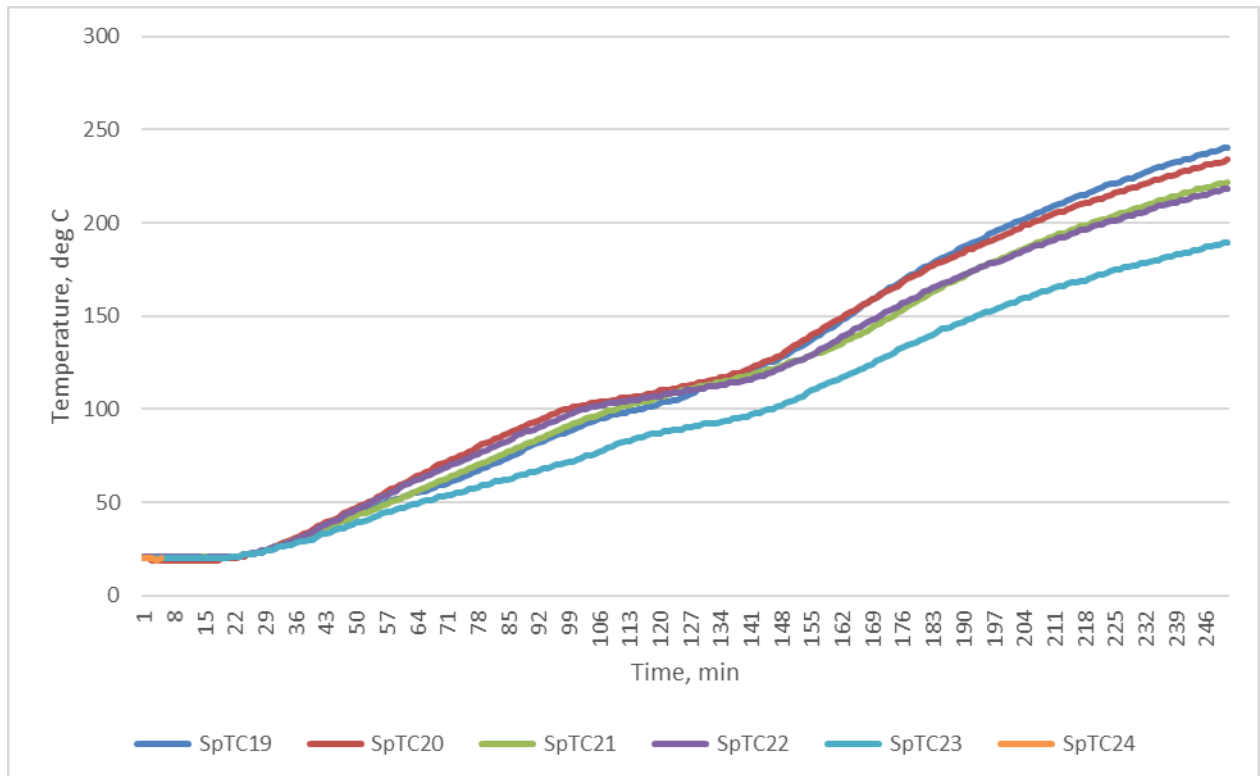

Roving thermocouple was applied to seal at 28 minutes, temperature exceeded 200°C - Insulation failure.

## 11. Additional photographs

---

### 11.1 During and after the test

**10 minutes:**



**30 minutes:**

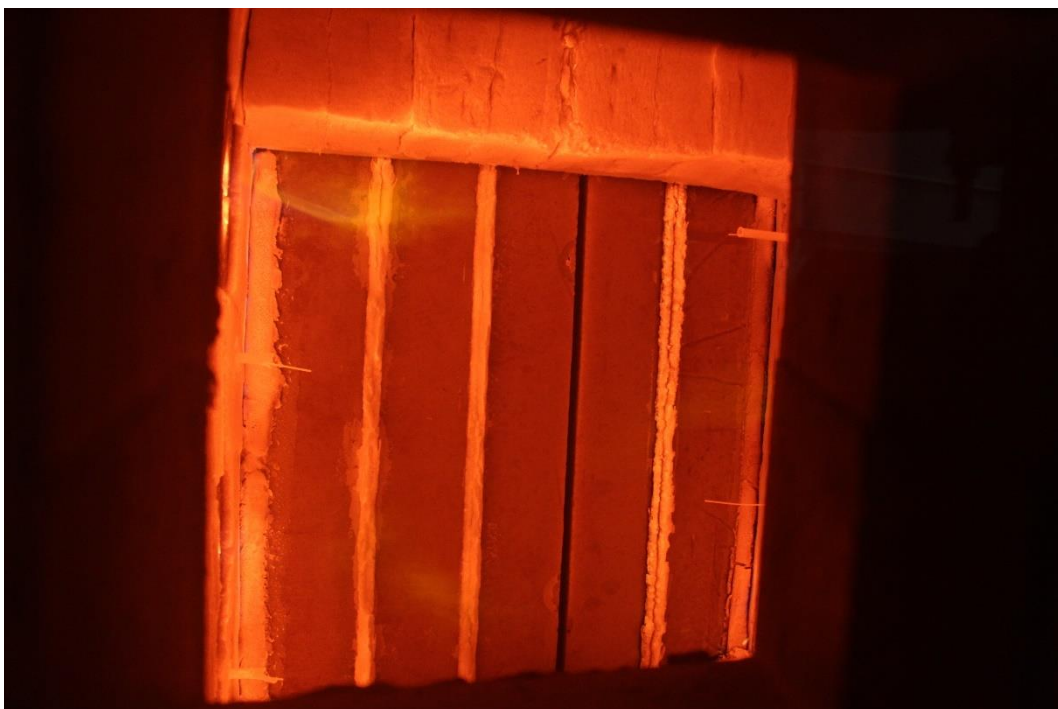

60 minutes:

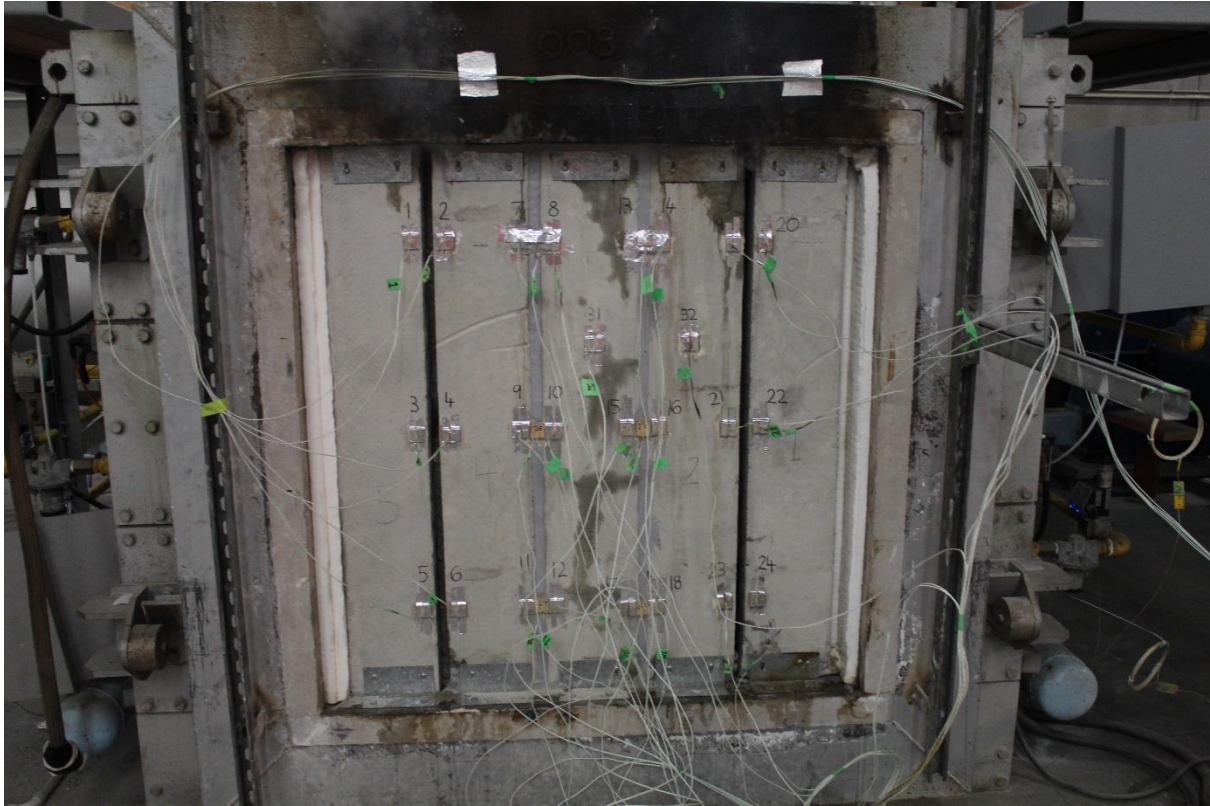



120 minutes:

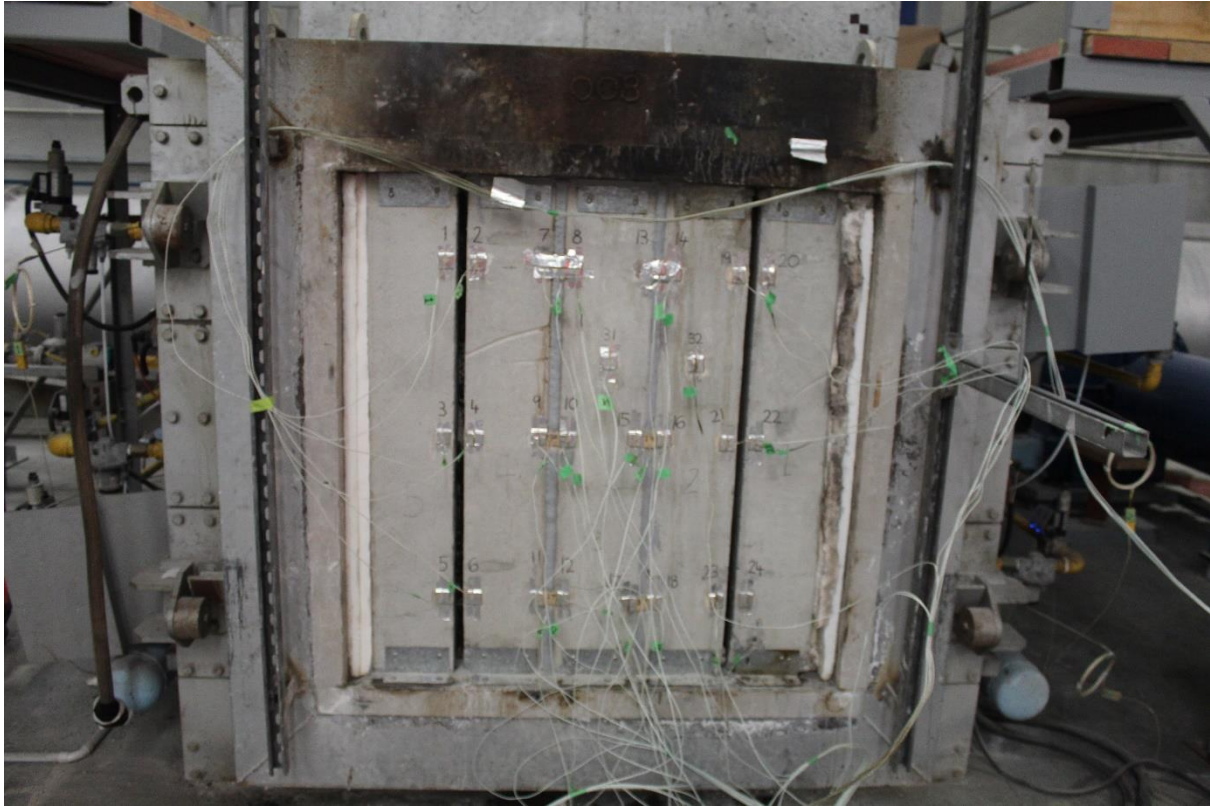

170 minutes:

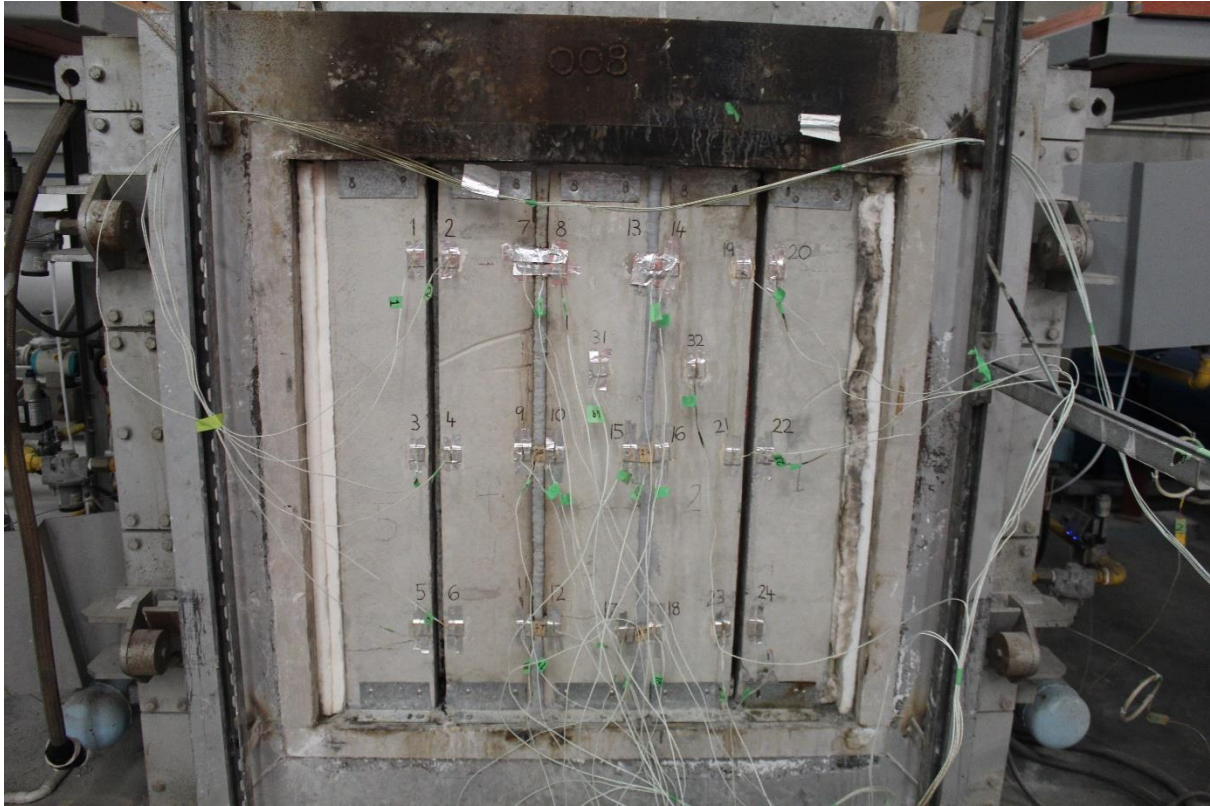



250 minutes:

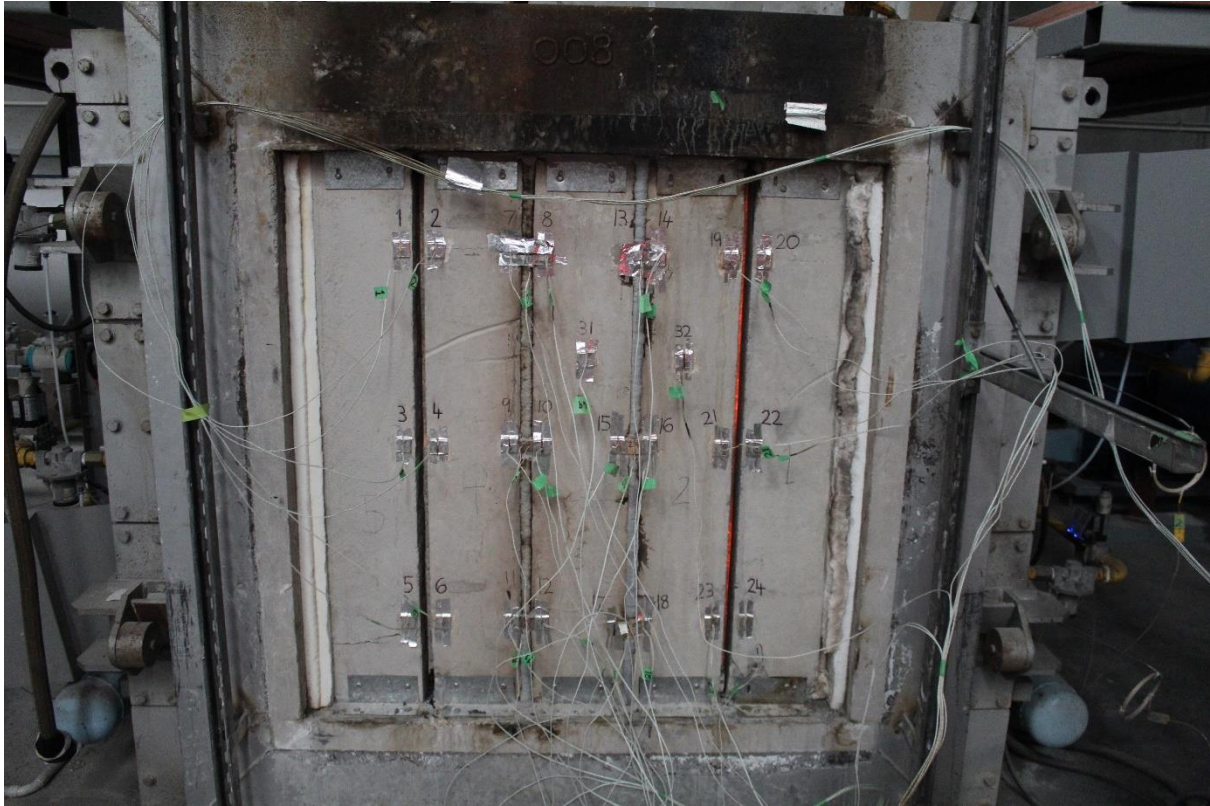

After the test:

